

THIS DRAWING CONTAINS INFORMATION PROPRIETARY TO RF INDUSTRIES.
 ANY UNAUTHORIZED USE OF THIS DRAWING IS EXPRESSLY PROHIBITED
 WITHOUT WRITTEN PERMISSION FROM RF INDUSTRIES.
 ANY VIOLATION IS PUNISHABLE UNDER U.S. COPYRIGHT LAWS.

ALL DIMENSIONS ARE REFERENCE ONLY

PART NO.

RSB-265-1

REV	DESCRIPTION	DWN	DATE	APPROVED
-	ENGINEERING RELEASE	CZS	8/2/00	JDMc

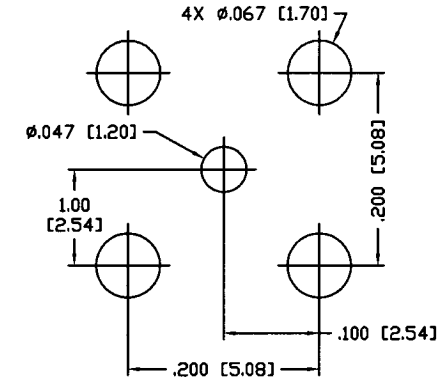
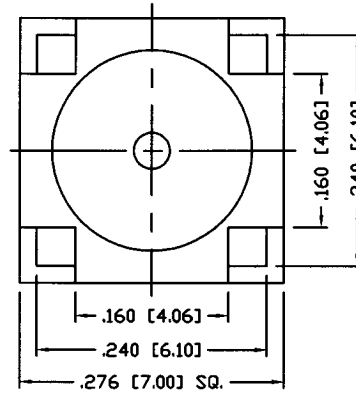
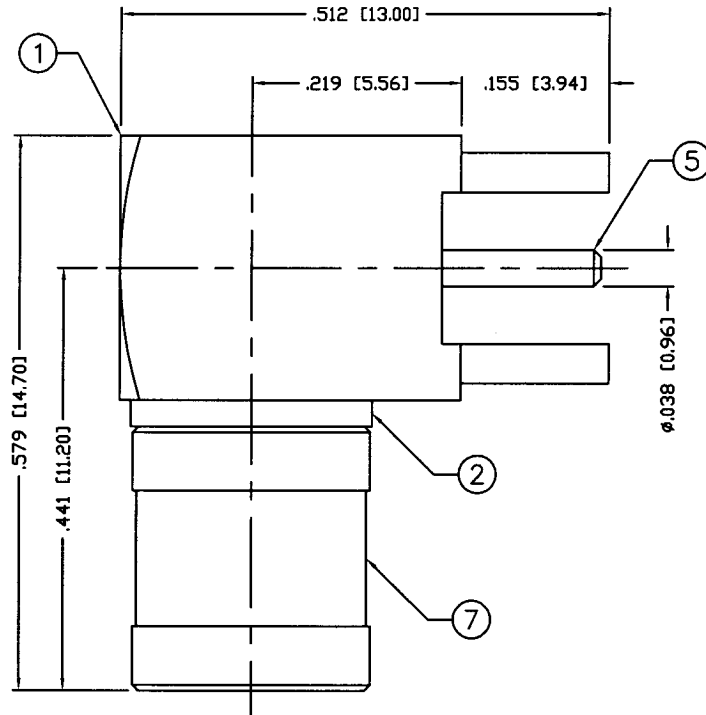

PCB MOUNTING HOLES

SPECIFICATIONS:

IMPEDANCE: 75 OHMS
 FREQUENCY: DC-4 GHz

1	BODY	1	BRASS	GOLD, 3 MICRO	008974	
2	HOUSING	1	BRASS	GOLD, 3 MICRO		
3	INSULATOR	1	PTFE	----		
4	INSULATOR	1	PTFE	----		
5	CONTACT	1	Be. Cu.	GOLD, 30 MICRO		
6	RETAINING RING	1	Be. Cu.	----		
7	SHELL	1	BRASS	GOLD, 3 MICRO		
8						
9						
10						
11						
12						
13						
14						
#	DESCRIPTION	QTY	MATRL	FINISH	APPROVALS	DATE

UNLESS OTHERWISE SPECIFIED:
 1. REMOVE ALL BURRS
 2. BREAK ALL CORNERS & EDGES .005 R. MAX.
 3. CHAMFER 1ST & LAST THREADS 45°
 4. SURFACE ROUGHNESS 63 FINISH MIL-STD-10
 5. DIAMETERS ON COMMON CENTERS TO BE CONCENTRIC WITHIN .002 T.I.R.
 6. ALL DIMENSIONS ARE AFTER PLATING.

DIMENSIONS ARE IN INCHES AND [MILLIMETERS]
 UNLESS OTHERWISE NOTED TOLERANCES ARE:

DECIMALS	DIAMETER
.XXX±.003 [.08]	.XXX±.001 [.03]
.XX±.005 [.13]	.XX±.003 [.08]

RF connectors DIVISION OF RF INDUSTRIES, LTD. 7610 MIRAMAR RD SAN DIEGO, CA 92126 (858) 549-6340 (858) 549-6345 FAX

MINI SMB PLUG

RIGHT ANGLE, 75 OHM, P.C. MOUNT

SIZE	CABLE GROUP	DWG NO.	REV
A	N/A	RSB-265-1	-
SCALE:	NTS	CAD FILE	OUTLINE
			SHEET 1 OF 1