

THIS DRAWING CONTAINS INFORMATION PROPRIETARY TO RF INDUSTRIES,  
 ANY UNAUTHORIZED USE OF THIS DRAWING IS EXPRESSLY PROHIBITED  
 WITHOUT WRITTEN PERMISSION FROM RF INDUSTRIES.  
 ANY VIOLATION IS PUNISHABLE UNDER U.S. COPYRIGHT LAWS.

ALL DIMENSIONS ARE REFERENCE ONLY

PART NO. <b>RSA-3252-1B</b>				
REV	DESCRIPTION	DWN	DATE	APPROVED
-	ENGINEERING RELEASE	CZS	8/20/04	JDMc

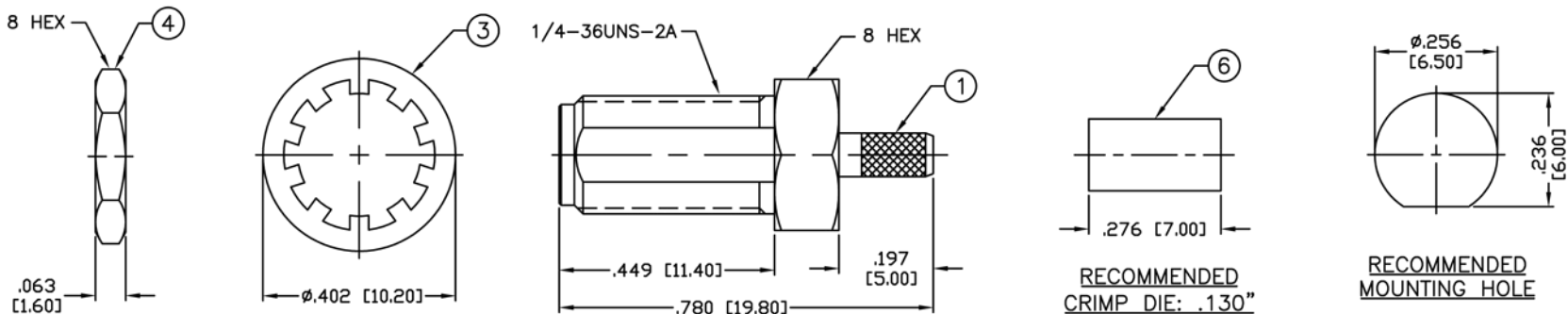

**SPECIFICATIONS:**

IMPEDANCE: 50 Ohms  
 FREQUENCY RANGE: 0-12.4 GHz  
 INSERTION LOSS(dB):  $0.06 \times \sqrt{f(\text{GHz})}$   
 WORKING VOLTAGE: 500 V rms Max. @ Sea Level  
 INSULATION RESISTANCE: 5k M Ohms min.  
 TEMPERATURE RANGE: -65°C TO 165°C  
 FOR RG-174, 188, 188A, 316/U, ALPHA 9174, 9316,  
 BELDEN 8216, 83269, 83284, 84316 & TIMES LMR-100A CABLE

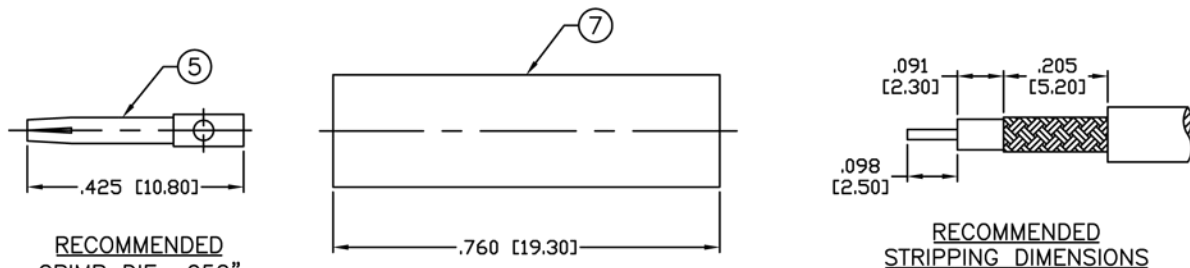

1	BODY	1	BRASS	GOLD, 3μ"	008974	
2	INSULATOR	1	PTFE	---		
3	LOCK WASHER	1	BRASS	GOLD, 3μ"		
4	HEX NUT	1	BRASS	GOLD, 3μ"		
5	CONTACT	1	Be-Cu	GOLD, 50μ"		
6	FERRULE	1	COPPER	GOLD, 3μ"		
7	TUBING	1	HEAT SHRINK	---		
8						
9						
10						
11						
12						
13						
14						
#	DESCRIPTION	QTY	MATRL	FINISH	APPROVALS	DATE

UNLESS OTHERWISE SPECIFIED:  
 1. REMOVE ALL BURRS  
 2. BREAK ALL CORNERS & EDGES .005 R. MAX.  
 3. CHAMFER 1ST & LAST THREADS 45°  
 4. SURFACE ROUGHNESS 63 FINISH MIL-STD-10  
 5. DIAMETERS ON COMMON CENTERS TO BE CONCENTRIC WITHIN .002 T.I.R.  
 6. ALL DIMENSIONS ARE AFTER PLATING.

DIMENSIONS ARE IN INCHES AND [MILLIMETERS]  
 UNLESS OTHERWISE NOTED TOLERANCES ARE:  
 DECIMALS      DIAMETER  
 .XXX±.003 [.08]      .XXX±.001 [.03]  
 .XX±.005 [.13]      .XX±.003 [.08]

**RF connectors**  
 DIVISION OF RF INDUSTRIES, LTD.  
 7610 MIRAMAR RD  
 SAN DIEGO, CA 92126  
 (858) 549-6340  
 (858) 549-6345 FAX

**SMA JACK, CRIMP**  
 BULKHEAD

SIZE	CABLE GROUP	DWG NO.	REV
A	B	RSA-3252-1B	-
SCALE: NTS		CAD FILE OUTLINE	SHEET 1 OF 1