

THIS DRAWING CONTAINS INFORMATION PROPRIETARY TO RF INDUSTRIES.
 ANY UNAUTHORIZED USE OF THIS DRAWING IS EXPRESSLY PROHIBITED
 WITHOUT WRITTEN PERMISSION FROM RF INDUSTRIES.
 ANY VIOLATION IS PUNISHABLE UNDER U.S. COPYRIGHT LAWS.

ALL DIMENSIONS ARE REFERENCE ONLY

PART NO.

RP-1212-C1

REV	DESCRIPTION	DWN	DATE	APPROVED
-	ENGINEERING RELEASE	GGG	12/6/00	JDMc

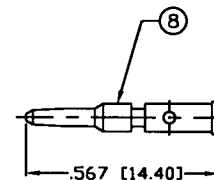
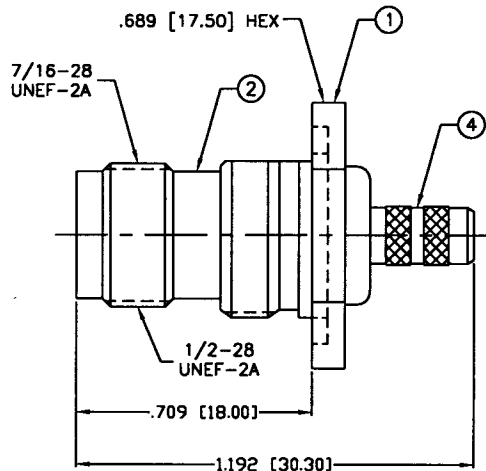
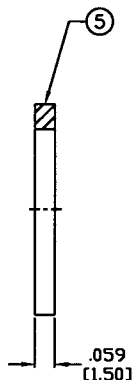
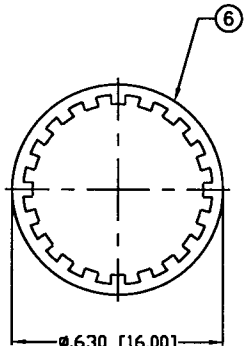
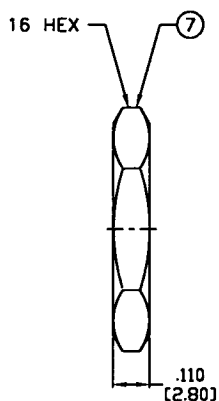

RECOMMENDED
CRIMP DIE: .068"

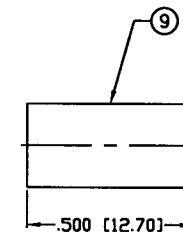

RECOMMENDED
CRIMP DIE: .213"

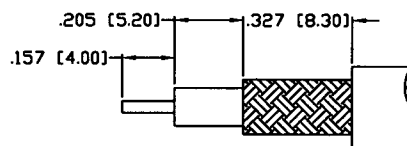

RECOMMENDED
STRIPPING DIMENSIONS

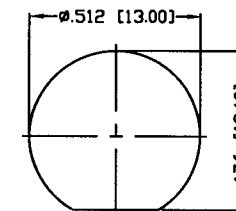

RECOMMENDED
MOUNTING HOLE

MAX. PANEL THICKNESS=.138 [3.50]

SPECIFICATIONS:

IMPEDANCE: 50 Ohms
 FREQUENCY RANGE: 0-11 GHz
 WORKING VOLTAGE: 500 VRMS
 INSULATION RESISTANCE: 5k M ohms min.
 TEMPERATURE RANGE: -65°C TO 85°C
 FOR RG-55, 55A, 55B, 142, 142A, 142B, 223/U & 400/U,
 ALPHA 9055, 9055B, 9223, BELDEN 8219, 83242, 84142, & 9907

1	BODY	1	BRASS	NICKEL, 100μ"
2	TNC BODY	1	BRASS	NICKEL, 100μ"
3	INSULATOR	1	PTFE	---
4	FERRULE STUD	1	BRASS	NICKEL, 100μ"
5	GASKET	1	RUBBER	---
6	LOCK WASHER	1	BRASS	NICKEL, 100μ"
7	HEX NUT	1	BRASS	NICKEL, 100μ"
8	CONTACT	1	BRASS	GOLD, 3μ"
9	FERRULE	1	BRASS	NICKEL, 100μ"
10				
11				
12				
13				
14				
#	DESCRIPTION	QTY	MATRL	FINISH

008974	
DRAWN	4/1/02
G. GALLEGOS	
CHECKED	4-1-02
ORJ DRAWN	
G. GALLEGOS	4/1/02
APPROVALS	DATE

UNLESS OTHERWISE SPECIFIED:
 1. REMOVE ALL BURRS
 2. BREAK ALL CORNERS & EDGES .005 R. MAX.
 3. CHAMFER 1ST & LAST THREADS 45°
 4. SURFACE ROUGHNESS 63 FINISH MIL-STD-10
 5. DIAMETERS ON COMMON CENTERS TO BE CONCENTRIC WITHIN .002 T.I.R.
 6. ALL DIMENSIONS ARE IN PLATING.

DIMENSIONS ARE IN INCHES AND [MILLIMETERS]
 UNLESS OTHERWISE NOTED TOLERANCES ARE:

DECIMALS	DIAMETER
.xxx±.003 [.08]	.xxx±.001 [.03]
.xx±.005 [.13]	.xx±.003 [.08]

RF connectors
 DIVISION OF RF INDUSTRIES, LTD.

7610 MIRAMAR RD
 SAN DIEGO, CA 92126
 (858) 549-6340
 (858) 549-6345 FAX

TNC JACK CRIMP

REVERSE POLARITY, BULKHEAD

SIZE	CABLE GROUP	DWG NO.	REV
A	C1	RP-1212-C1	-
SCALE:	NTS	CAD FILE	OUTLINE
SHEET 1 OF 1			