

THIS DRAWING CONTAINS INFORMATION PROPRIETARY TO RF INDUSTRIES,
 ANY UNAUTHORIZED USE OF THIS DRAWING IS EXPRESSLY PROHIBITED
 WITHOUT WRITTEN PERMISSION FROM RF INDUSTRIES.
 ANY VIOLATION IS PUNISHABLE UNDER U.S. COPYRIGHT LAWS.

ALL DIMENSIONS ARE REFERENCE ONLY

PART NO.

RP-1202-C2

REV	DESCRIPTION	DWN	DATE	APPROVED
-	ENGINEERING RELEASE	CZS	12/29/00	JDMc

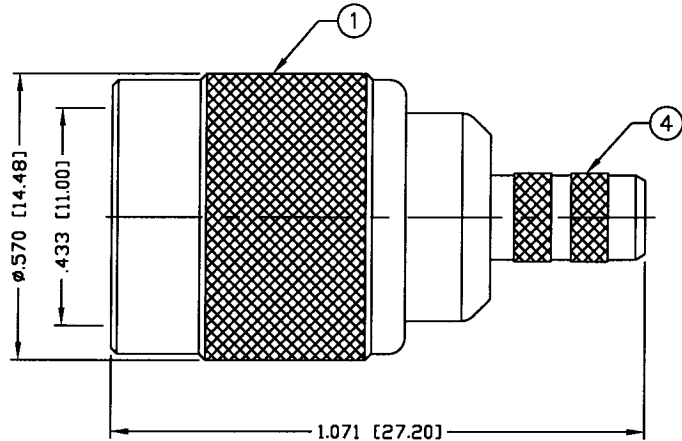

RECOMMENDED CRIMP DIE: .068"

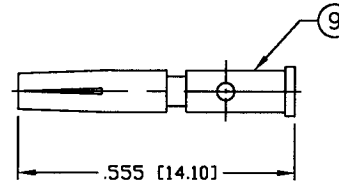

RECOMMENDED CRIMP DIE: .213"

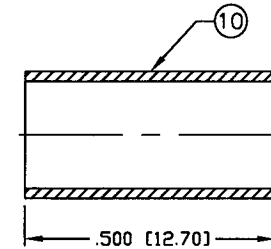

SPECIFICATIONS:

IMPEDANCE: 50 Ohms
 FREQUENCY RANGE: 0-7 GHz
 WORKING VOLTAGE: 500 V rms @ sea level
 INSULATION RESISTANCE: 5k M ohms min.
 TEMPERATURE RANGE: -65°C TO +85°C
 FOR TIMES LMR-200, ALPHA 9848 & MSI-22

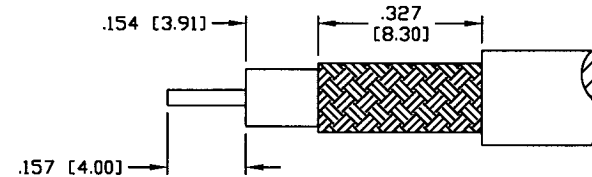

RECOMMENDED STRIPPING DIMENSIONS

#	DESCRIPTION	QTY	MATERIAL	FINISH	APPROVALS	DATE
1	SHELL	1	BRASS	NICKEL, 100μ"	008974	4/2/03
2	BODY	1	BRASS	NICKEL, 100μ"		
3	INSULATOR	1	PTFE	---		
4	FERRULE STUD	1	BRASS	NICKEL, 100μ"		
5	GASKET	1	RUBBER	---		
6	RETAINING RING	1	BRASS	NICKEL, 100μ"		
7	RING	1	DELRIN	---		
8	WASHER	1	BRASS	NICKEL, 100μ"		
9	CONTACT	1	PHOS. BRONZE	GOLD, 3μ"		
10	FERRULE	1	BRASS	NICKEL, 100μ"		
11						
12						
13						
14						

DRAWN	C. ZUNIGA	4/2/03
CHECKED	JDMc	4/2/03
ORJ DRAWN	C. ZUNIGA	4/2/03

UNLESS OTHERWISE SPECIFIED:
 1. REMOVE ALL BURRS
 2. BREAK ALL CORNERS & EDGES .005 R. MAX.
 3. CHAMFER 1ST & LAST THREADS 45°
 4. SURFACE ROUGHNESS 63 FINISH MIL-STD-10
 5. DIAMETERS ON COMMON CENTERS TO BE CONCENTRIC WITHIN .002 T.I.R.
 6. ALL DIMENSIONS ARE AFTER PLATING.

DIMENSIONS ARE IN INCHES AND [MILLIMETERS]
 UNLESS OTHERWISE NOTED TOLERANCES ARE:
 DECIMALS DIAMETER
 .xxx±.003 [.08] .xxx±.001 [.03]
 .xx±.005 [.13] .xx±.003 [.08]

RF

7610 MIRAMAR RD
 SAN DIEGO, CA 92126
 (858) 549-6340
 (858) 549-6345 FAX

DIVISION OF RF INDUSTRIES, LTD.

TNC PLUG, CRIMP

REVERSE POLARITY

SIZE A	CABLE GROUP C2	DWG NO. RP-1202-C2	REV -
------------------	--------------------------	------------------------------	-----------------

SCALE: NTS
CAD FILE OUTLINE
SHEET 1 OF 1