

THIS DRAWING CONTAINS INFORMATION PROPRIETARY TO RF INDUSTRIES,  
 ANY UNAUTHORIZED USE OF THIS DRAWING IS EXPRESSLY PROHIBITED  
 WITHOUT WRITTEN PERMISSION FROM RF INDUSTRIES.  
 ANY VIOLATION IS PUNISHABLE UNDER U.S. COPYRIGHT LAWS.

ALL DIMENSIONS ARE REFERENCE ONLY

PART NO.		<b>RHV-116</b>		
REV	DESCRIPTION	DWN	DATE	APPROVED
-	ENGINEERING RELEASE	CZS	8/22/96	CZS

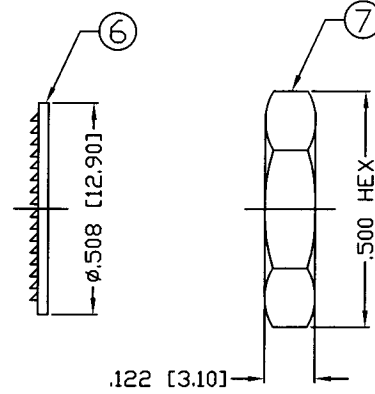
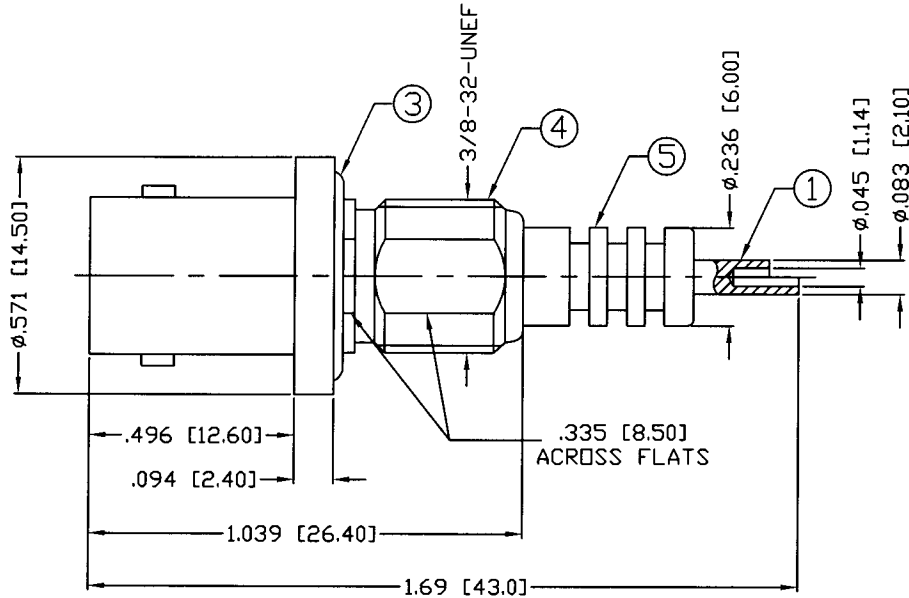

RECOMMENDED MOUNTING HOLE

**SPECIFICATIONS:**

IMPEDANCE: NON CONSTANT  
 WORKING VOLTAGE: 5000 V rms @ sea level (mated)  
 TEMPERATURE RANGE: -65°C TO 85°C  
 INSULATION RESISTANCE: 5k M Ohms min.

1	CONTACT	1	BRASS	GOLD, 3μ"	007777	
2	INSULATOR	1	PTFE	---		
3	O-RING	1	RUBBER	---		
4	BODY	1	BRASS	NICKEL, 100μ"		
5	INSULATOR	1	PTFE	---		
6	WASHER	1	IRON	NICKEL, 100μ"		
7	HEX NUT	1	BRASS	NICKEL, 100μ"		
8						
9						
10						
11						
12						
13						
14						
#	DESCRIPTION	QTY	MATERIAL	FINISH	APPROVALS	DATE

DRAWN	C. ZUNIGA	12/12/01
CHECKED	<i>[Signature]</i>	12/13/01
ORJ DRAWN	C. ZUNIGA	12/12/01

UNLESS OTHERWISE SPECIFIED:  
 1. REMOVE ALL BURRS  
 2. BREAK ALL CORNERS & EDGES .005 R. MAX.  
 3. CHAMFER 1ST & LAST THREADS 45°  
 4. SURFACE ROUGHNESS 63 FINISH MIL-STD-10  
 5. DIAMETERS ON COMMON CENTERS TO BE CONCENTRIC WITHIN .002 T.I.R.  
 6. ALL DIMENSIONS ARE AFTER PLATING.

DIMENSIONS ARE IN INCHES AND [MILLIMETERS]  
 UNLESS OTHERWISE NOTED TOLERANCES ARE:  
 DECIMALS      DIAMETER  
 .XXX±.003 [.08]      .XXX±.001 [.03]  
 .XX±.005 [.13]      .XX±.003 [.08]

RF

7610 MIRAMAR RD  
 SAN DIEGO, CA 92126  
 (858) 549-6340  
 (858) 549-6345 FAX

DIVISION OF RF INDUSTRIES, LTD.

## MHV JACK

BULKHEAD, FRONT MOUNT

SIZE	CABLE GROUP	DWG NO.	REV
A	N/A	RHV-116	—

SCALE: NTS
CAD FILE OUTLINE
SHEET 1 OF 1