

THIS DRAWING CONTAINS INFORMATION PROPRIETARY TO RF INDUSTRIES.
 ANY UNAUTHORIZED USE OF THIS DRAWING IS EXPRESSLY PROHIBITED
 WITHOUT WRITTEN PERMISSION FROM RF INDUSTRIES.
 ANY VIOLATION IS PUNISHABLE UNDER U.S. COPYRIGHT LAWS.

ALL DIMENSIONS ARE REFERENCE ONLY

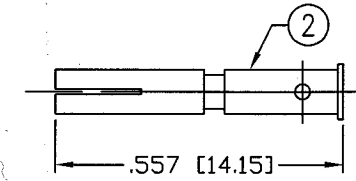

RECOMMENDED CRIMP DIE: .068

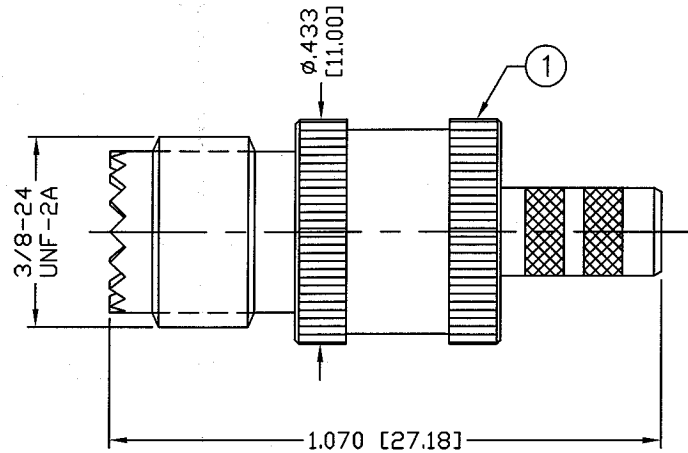
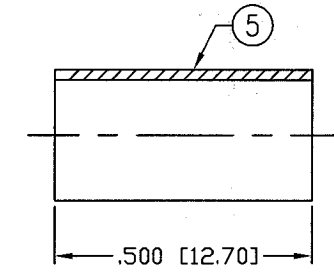

RECOMMENDED CRIMP DIE: .213

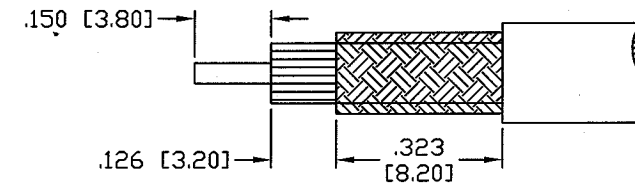

RECOMMENDED STRIPPING INSTRUCTIONS

SPECIFICATIONS:

IMPEDANCE: 50 Ohms
 FREQUENCY RANGE: 0-2.5 GHz
 VSWR: 1.25 MAX.
 WORKING VOLTAGE: 335 V rms Max. @ Sea Level
 INSULATION RESISTANCE: 5k M Ohms min.
 TEMPERATURE RANGE: -65°C TO 165°C
 FOR RG-58, 58A, 58C, 141, 141A, BELDEN 8240,
 8259, 8262, 9201, 9203, 9310, 9311 & COMM/SCOPE 0268

1	BODY	1	BRASS	NICKEL, 80μ"
2	CONTACT	1	BRASS	SILVER, 5μ"
3	INSULATOR	1	PTFE	---
4	PRESS WASHER	1	BRASS	NICKEL, 80μ"
5	FERRULE	1	BRASS	NICKEL, 80μ"
6				
7				
8				
9				
10				
11				
12				
13				
14				
#	DESCRIPTION	QTY	MATERIAL	FINISH

000486	
DRAWN C. ZUNIGA	12/14/01
CHECKED <i>[Signature]</i>	12/14/01
ORJ DRAWN P. BREAUX	3/12/92
APPROVALS	DATE

UNLESS OTHERWISE SPECIFIED:
 1. REMOVE ALL BURRS
 2. BREAK ALL CORNERS & EDGES .005 R. MAX.
 3. CHAMFER 1ST & LAST THREADS 45°
 4. SURFACE ROUGHNESS 63 FINISH MIL-STD-10
 5. DIAMETERS ON COMMON CENTERS TO BE CONCENTRIC WITHIN .002 T.I.R.
 6. ALL DIMENSIONS ARE AFTER PLATING.

DIMENSIONS ARE IN INCHES AND [MILLIMETERS]
 UNLESS OTHERWISE NOTED TOLERANCES ARE:
 DECIMALS DIAMETER
 .xxx±.003 [.08] .xxx±.001 [.03]
 .xx±.005 [-13] .xx±.003 [.08]

RF connectors
 DIVISION OF RF INDUSTRIES, LTD.

7610 MIRAMAR RD
 SAN DIEGO, CA 92126
 (858) 549-6340
 (858) 549-6345 FAX

MINI UHF JACK, CRIMP

SIZE A	CABLE GROUP C	DWG NO. RFU-601-1	REV J
SCALE: NTS		CAD FILE OUTLINE	SHEET 1 OF 1