

THIS DRAWING CONTAINS INFORMATION PROPRIETARY TO RF INDUSTRIES,
 ANY UNAUTHORIZED USE OF THIS DRAWING IS EXPRESSLY PROHIBITED
 WITHOUT WRITTEN PERMISSION FROM RF INDUSTRIES.
 ANY VIOLATION IS PUNISHABLE UNDER U.S. COPYRIGHT LAWS.

PART NO.

RFU-521-ST

| REV | DESCRIPTION | DWN | DATE | APPROVED |
|-----|---------------------|-----|---------|----------|
| - | ENGINEERING RELEASE | CZS | 9/26/00 | JDMc |
| | | | | |
| | | | | |

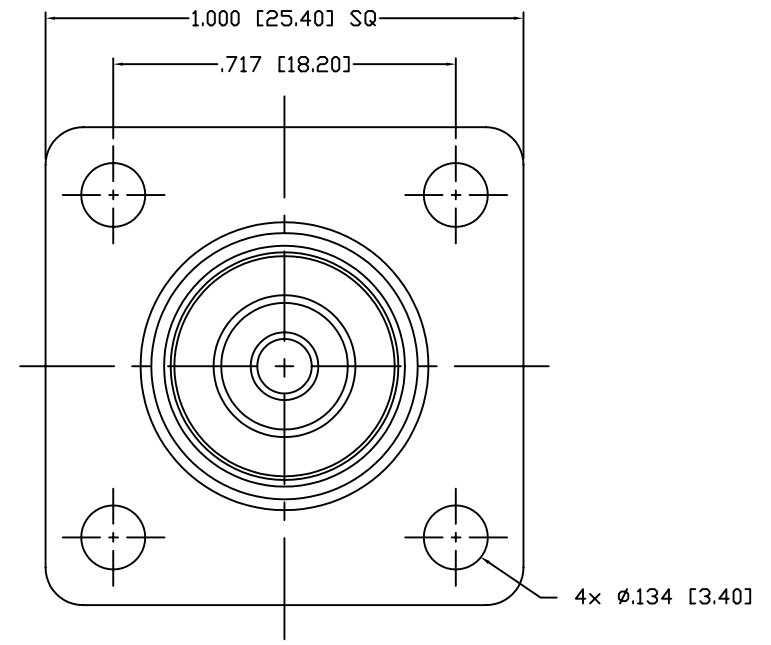
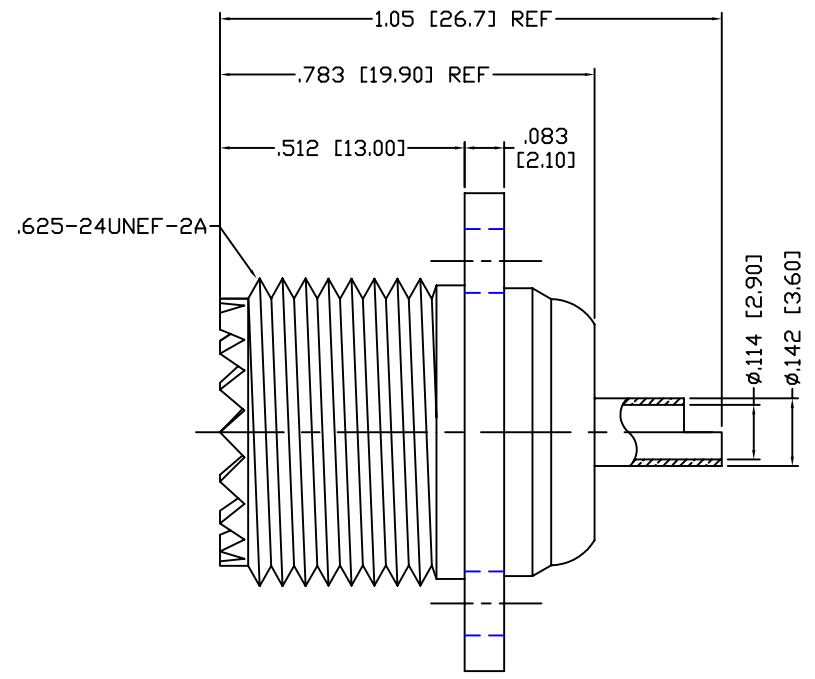

SPECIFICATIONS:

IMPEDANCE: NON CONSTANT

ALL DIMENSIONS ARE REFERENCE ONLY

| | | | | | | |
|----|-------------|-----|---------|------------------|-----------|------|
| 1 | BODY | 1 | DIECAST | SILVER, 30 MICRO | 00486 | |
| 2 | INSULATOR | 1 | PTFE | --- | | |
| 3 | CONTACT | 1 | BRASS | GOLD, 3 MICRO | | |
| 4 | | | | | | |
| 5 | | | | | | |
| 6 | | | | | | |
| 7 | | | | | | |
| 8 | | | | | | |
| 9 | | | | | | |
| 10 | | | | | | |
| 11 | | | | | | |
| 12 | | | | | | |
| 13 | | | | | | |
| 14 | | | | | | |
| # | DESCRIPTION | QTY | MATRL | FINISH | APPROVALS | DATE |

UNLESS OTHERWISE SPECIFIED:
 1. REMOVE ALL BURRS
 2. BREAK ALL CORNERS & EDGES .005 R. MAX.
 3. CHAMFER 1ST & LAST THREADS 45°
 4. SURFACE ROUGHNESS 63 FINISH MIL-STD-10
 5. DIAMETERS ON COMMON CENTERS TO BE CONCENTRIC WITHIN .002 T.I.R.
 6. ALL DIMENSIONS ARE AFTER PLATING.

DIMENSIONS ARE IN INCHES AND [MILLIMETERS]
 UNLESS OTHERWISE NOTED TOLERANCES ARE:

| DECIMALS | DIAMETER |
|-----------------|-----------------|
| .XXX±.003 [.08] | .XXX±.001 [.03] |
| .XX±.005 [.13] | .XX±.003 [.08] |

RF connectors
 DIVISION OF RF INDUSTRIES, LTD.

7610 MIRAMAR RD
 SAN DIEGO, CA 92126
 (858) 549-6340
 (858) 549-6345 FAX

UHF JACK
 4 HOLE FLANGE WITH SOLDER CUP

| SIZE | CABLE GROUP | DWG NO. | REV |
|------|-------------|------------|-----|
| A | N/A | RFU-521-ST | - |

SCALE: NTS CAD FILE OUTLINE SHEET 1 OF 1