

THIS DRAWING CONTAINS INFORMATION PROPRIETARY TO RF INDUSTRIES.  
 ANY UNAUTHORIZED USE OF THIS DRAWING IS EXPRESSLY PROHIBITED  
 WITHOUT WRITTEN PERMISSION FROM RF INDUSTRIES.  
 ANY VIOLATION IS PUNISHABLE UNDER U.S. COPYRIGHT LAWS.

ALL DIMENSIONS ARE REFERENCE ONLY

PART NO.

**RFT-1213-X**

REV	DESCRIPTION	DWN	DATE	APPROVED
A	ENGINEERING RELEASE	CZS	6/19/00	JDMc
B	CHANGE STRIPPING DIMENSIONS / CHANGE TO 000486	CZS	11/02/01	JDMc

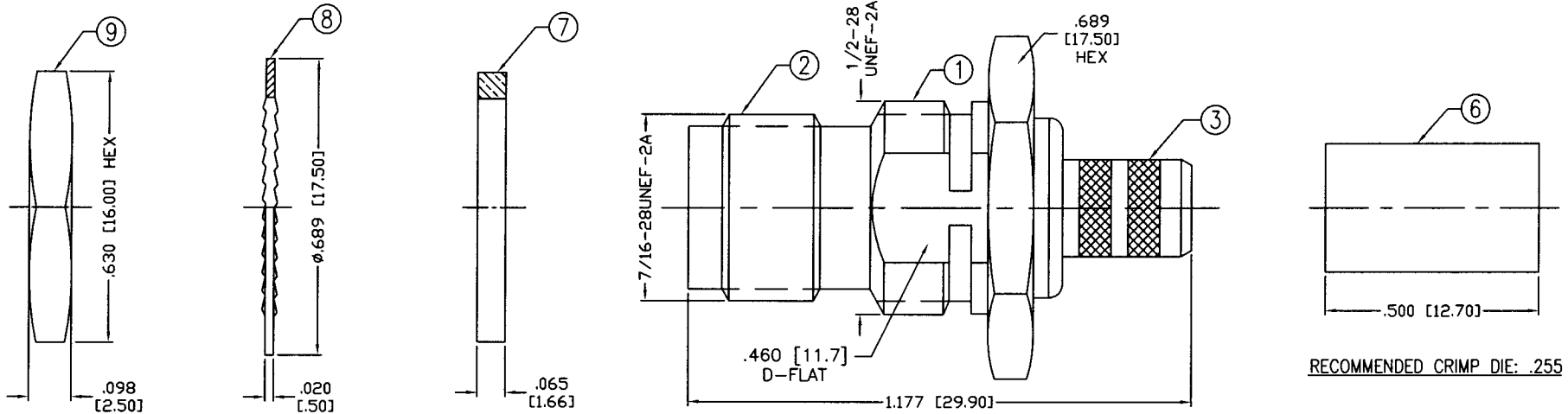

**SPECIFICATIONS:**

IMPEDANCE: 50 Ohms  
 FREQUENCY RANGE: 0-7 GHz  
 WORKING VOLTAGE: 500 V rms @ sea level  
 INSULATION RESISTANCE: 5k M ohms min.  
 TEMPERATURE RANGE: -65°C TO +165°C  
 FOR RG-8/X, BELDEN 9258, MAXRAD M8X-100 &  
 M8X-1000, MICRO 8/U, REMEE 1600, SAXTON 8315 &  
 TIMES LMR-240 & LMR-240 ULTRAFLEX CABLE

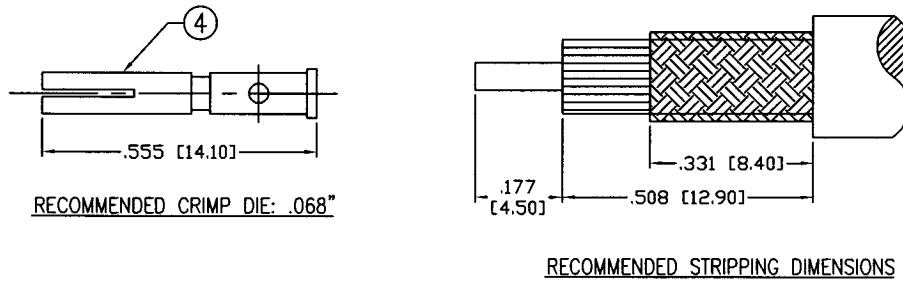

1	BODY	1	BRASS	NICKEL, 100μ"	000486	
2	PRESS BODY	1	BRASS	NICKEL, 100μ"		
3	FERRULE STUD	1	BRASS	NICKEL, 100μ"		
4	PIN	1	BRASS	GOLD, 3μ"		
5	INSULATOR	1	DELTRIN	---		
6	FERRULE	1	BRASS	NICKEL, 100μ"		
7	GASKET	1	RUBBER	----		
8	LOCK WASHER	1	BRASS	NICKEL, 100μ"		
9	HEX NUT	1	BRASS	NICKEL, 100μ"		
10					DRAWN C. ZUNIGA 3/11/04	
11						CHECKED <i>[Signature]</i> 3-11-04
12						
13						ORJ DRAWN C. ZUNIGA 6/19/00
#	DESCRIPTION	QTY	MATERIAL	FINISH	APPROVALS	DATE

UNLESS OTHERWISE SPECIFIED:  
  
 DIMENSIONS ARE IN INCHES  
 AND [MILLIMETERS]  
 UNLESS OTHERWISE NOTED  
 TOLERANCES ARE:  
 DECIMALS      DIAMETER

**RF connectors**  
 DIVISION OF RF INDUSTRIES, LTD.

7610 MIRAMAR RD  
 SAN DIEGO, CA 92126  
 (858) 549-6340  
 (858) 549-6345 FAX

**TNC JACK CRIMP**  
 BULKHEAD

SIZE A	CABLE GROUP X	DWG NO. RFT-1213-X	REV B
SCALE: NTS		CAD FILE OUTLINE	SHEET 1 OF 1