

ENVELOPE / ASSEMBLY DRAWING

007777

SPECIFICATION CONTROL DRAWING

THIS DRAWING CONTAINS INFORMATION PROPRIETARY TO RF INDUSTRIES, LTD. ANY UNAUTHORIZED USE OF THIS DRAWING IS EXPRESSLY PROHIBITED. ANY VIOLATION IS PUNISHABLE UNDER U.S. COPYRIGHT LAWS.

REV	DESCRIPTION	DWN	DATE	APPROVED
A	ENGINEERING RELEASE	CZS	6/7/99	R. RICE

ALL DIMENSIONS ARE REFERENCE ONLY

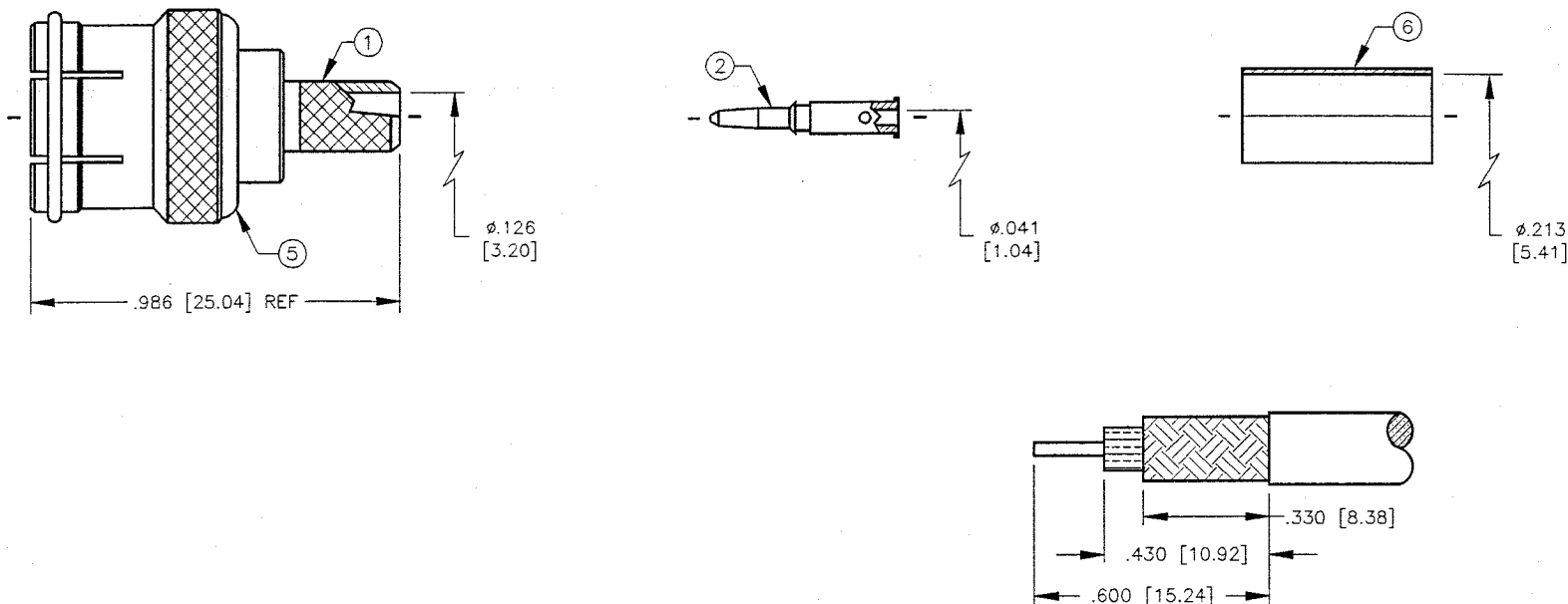

SPECIFICATIONS:

IMPEDANCE: 50 OHMS
 WORKING VOLTAGE: 500 VRMS @ SEA LEVEL
 FREQUENCY RANGE: 0-7 GHz
 INSERTION LOSS: \leq -.2 dB @ 3 GHz
 VSWR MAX: 1.3:1 @ 3 GHz
 FOR RG-58, 58A, 58C, 141, 141A, 400/U, BELDEN 8240, 8259, 8262, 9201, 9203, 9310, 9311, COMM/SCOPE 0268 & CUSHCRAFT ULTRALINK TL92463E INTERFACE PER MIL-STD-348A, SECTION 313.1

SUGGESTED STRIPPING INSTRUCTIONS

SUGGESTED CRIMP DIE: .068 & .213

DIMENSIONS ARE IN INCHES AND [MILLIMETERS]

UNLESS OTHERWISE NOTED TOLERANCES ARE:
 DECIMALS DIAMETER

RF connectors
 DIVISION OF RF INDUSTRIES, LTD.

7610 MIRAMAR RD
 SAN DIEGO, CA 92126
 (619)549-6340
 (619)549-6345 FAX

RFT-1202-5

TNC MALE CRIMP, QUICK DISCONNECT

ITEM	DESCRIPTION	QTY	MATERIAL	FINISH
6	FERRULE	1	BRASS	NICKEL
5	SHELL	1	BRASS	NICKEL
4	SPRING	1	SW	NICKEL
3	DIELECTRIC	1	DELTRIN	NONE
2	PIN	1	BRASS	GOLD
1	BODY	1	BRASS	NICKEL

DRAWN C. ZUNIGA	6/7/99
CHECKED <i>C. Zuniga</i>	6/17/99
OR DRAWN C. ZUNIGA	6/7/99

SIZE A	CABLE GROUP C	DWG NO. 9191	REV A
SCALE: 2:1		CAD FILE 13ARC B	SHEET 1 OF 1