

THIS DRAWING CONTAINS INFORMATION PROPRIETARY TO RF INDUSTRIES,
 ANY UNAUTHORIZED USE OF THIS DRAWING IS EXPRESSLY PROHIBITED
 WITHOUT WRITTEN PERMISSION FROM RF INDUSTRIES.
 ANY VIOLATION IS PUNISHABLE UNDER U.S. COPYRIGHT LAWS.

PART NO.

RFN-1006-9L2

REV	DESCRIPTION	DWN	DATE	APPROVED
-	ENGINEERING RELEASE	CZS	1/20/09	JDMc

ALL DIMENSIONS ARE REFERENCE ONLY

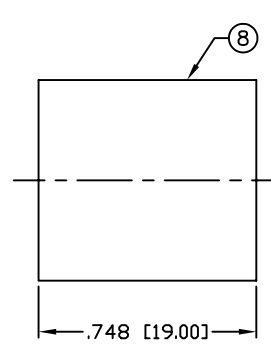
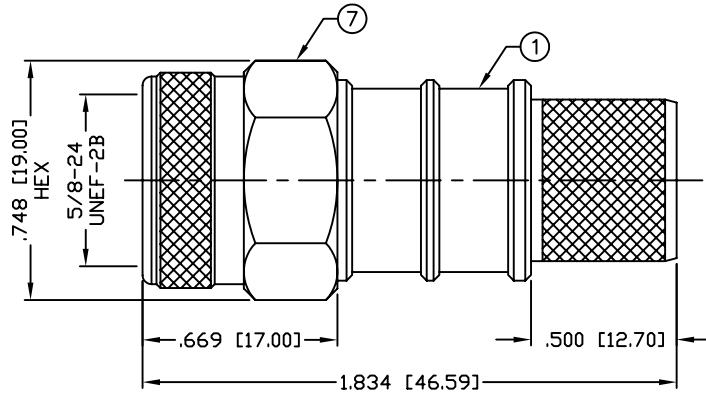

RECOMMENDED CRIMP DIE: .610"

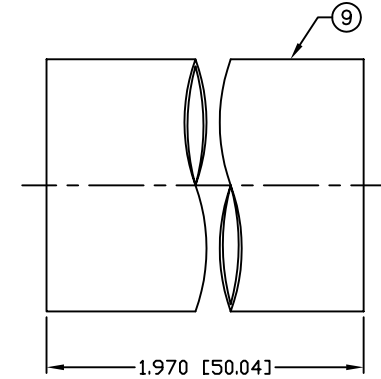

SPECIFICATIONS:

IMPEDANCE: 50 Ohms
 FREQUENCY RANGE: 0-11 GHz
 WORKING VOLTAGE: 1K V rms Max. @ Sea Level
 VSWR MAX: 1.3
 INSERTION LOSS(dB): $0.6 \times \sqrt{f(\text{GHz})}$
 CONTACT RESISTANCE: ≤ 6 m Ohm
 INSULATION RESISTANCE: xxk M Ohms min.
 TEMPERATURE RANGE: -65°C TO 85°C
 FOR TIMES LMR-600, LMR-600 ULTRAFLEX & T-COM-600

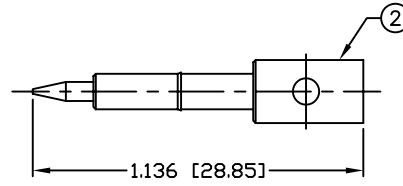

RECOMMENDED CRIMP DIE: .184"

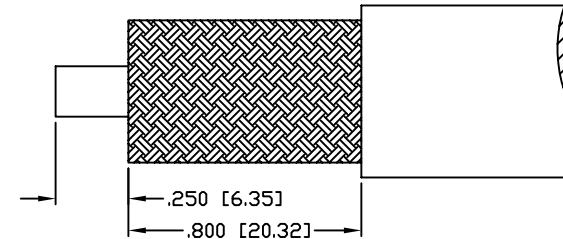

RECOMMENDED STRIPPING DIMENSIONS

14					
13					
12					
11					
10					
9	TUBING	1	HEAT SHRINK	---	
8	FERRULE	1	BRASS	WHITE BRONZE	
7	SHELL	1	BRASS	WHITE BRONZE	
6	GASKET	1	SI RUBBER	---	
5	SPLIT LOCK WASHER	1	BRASS	WHITE BRONZE	
4	GROUND RING	1	BRASS	WHITE BRONZE	
3	INSULATOR	1	PTFE	---	
2	PIN	1	BRASS	GOLD, 3μ"	
1	BODY	1	BRASS	WHITE BRONZE	
#	DESCRIPTION	QTY	MATERIAL	FINISH	

000494	
DRAWN	C. ZUNIGA
CHECKED	
ORJ DRAWN	C. ZUNIGA
DATE	03/13/09
APPROVALS	DATE

RoHS COMPLIANT

DIMENSIONS ARE IN INCHES AND [MILLIMETERS]
 UNLESS OTHERWISE NOTED TOLERANCES ARE:
 DECIMALS | DIAMETER

RF connectors
 DIVISION OF RF INDUSTRIES, LTD.

7610 MIRAMAR RD
 SAN DIEGO, CA 92126
 (858) 549-6340
 (858) 549-6345 FAX

N PLUG, CRIMP

SIZE	CABLE GROUP	DWG NO.	REV
A	L2	RFN-1006-9L2	-
SCALE:	NTS	CAD FILE OUTLINE	SHEET 1 OF 1