

THIS DRAWING CONTAINS INFORMATION PROPRIETARY TO RF INDUSTRIES.
 ANY UNAUTHORIZED USE OF THIS DRAWING IS EXPRESSLY PROHIBITED
 WITHOUT WRITTEN PERMISSION FROM RF INDUSTRIES.
 ANY VIOLATION IS PUNISHABLE UNDER U.S. COPYRIGHT LAWS.

ALL DIMENSIONS ARE REFERENCE ONLY

PART NO.

RFN-1005-B1-03

REV	DESCRIPTION	DWN	DATE	APPROVED
A	ENGINEERING RELEASE	CZS	3/16/99	R. RICE
B	CHANGE DRAWING NUMBER / UPDATE DWG FORMAT	CZS	6/14/01	JDMc

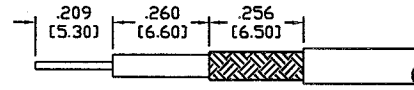
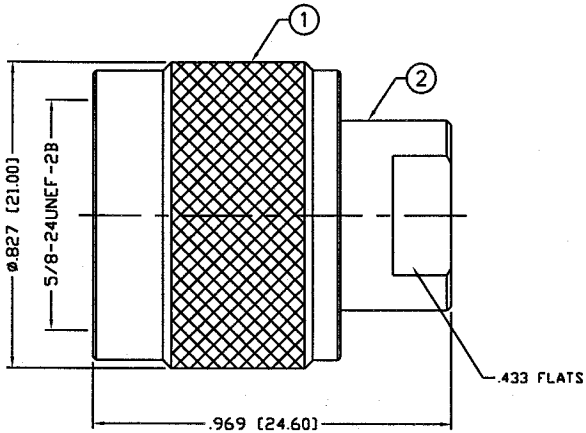

RECOMMENDED STRIPPING DIM'S

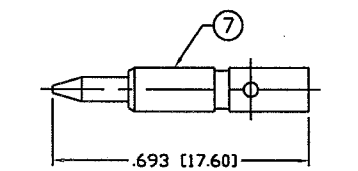

RECOMMENDED CRIMP SIZE .100

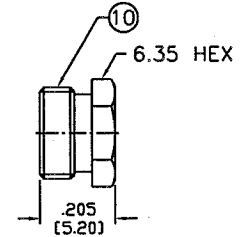
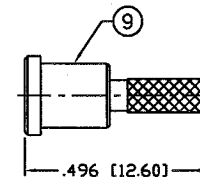
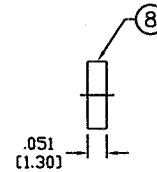

SPECIFICATIONS:

IMPEDANCE: 50 OHMS
 FREQUENCY RANGE: 0-11 GHz
 VSWR: 1.3 Max.
 INSERTION LOSS: .06 dB Max. $X\sqrt{fGHz}$
 WORKING VOLTAGE: 1k V rms @ sea level
 TEMPERATURE RANGE: -65°C TO 165°C
 INSULATION RESISTANCE: 5k M Ohms min.
 FOR RG-316/U DOUBLE SHIELD CABLE

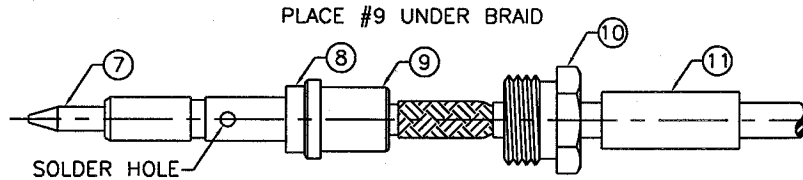

NOTE COMPONENTS THAT MUST BE IN PLACE BEFORE INSERTING PIN INTO CONNECTOR

RECOMMENDED CRIMP SIZE .137

1	COUPLING NUT	1	BRASS	NICKEL, 100 μ "
2	BODY	1	BRASS	NICKEL, 100 μ "
3	INSULATOR	1	PTFE	----
4	GROUND RING	1	BRASS	NICKEL, 100 μ "
5	GASKET	1	SILICONE	RED
6	RETAINING RING	1	SUS 304	----
7	PIN	1	BRASS	GOLD, 3 μ "
8	INSULATOR	1	PTFE	----
9	FERRULE STUD	1	BRASS	NICKEL, 100 μ "
10	HEX NUT	1	BRASS	NICKEL, 100 μ "
11	FERRULE	1	BRASS	NICKEL, 100 μ "
12				
13				
14				
#	DESCRIPTION	QTY	MATERIAL	FINISH

008974	
DRAWN C. ZUNIGA	6/14/01
CHECKED <i>[Signature]</i>	7-20-01
ORJ DRAWN C. ZUNIGA	3/16/99
APPROVALS	DATE

UNLESS OTHERWISE SPECIFIED:
 1. REMOVE ALL BURRS
 2. BREAK ALL CORNERS & EDGES .005 R. MAX.
 3. CHAMFER 1ST & LAST THREADS 45°
 4. SURFACE ROUGHNESS 63 FINISH MIL-STD-10
 5. DIAMETERS ON COMMON CENTERS TO BE CONCENTRIC WITHIN .002 T.I.R.
 6. ALL DIMENSIONS ARE AFTER PLATING.

DIMENSIONS ARE IN INCHES AND [MILLIMETERS]
 UNLESS OTHERWISE NOTED TOLERANCES ARE:

DECIMALS	DIAMETER
.xxx±.003 [.08]	.xxx±.001 [.03]
.xx±.005 [.13]	.xx±.003 [.08]

RF connectors
 DIVISION OF RF INDUSTRIES, LTD.

7610 MIRAMAR RD
 SAN DIEGO, CA 92126
 (858) 549-6340
 (858) 549-6345 FAX

N CRIMP MALE

SIZE A	CABLE GROUP B1	DWG NO. RFN-1005-B1-03	REV B
SCALE: NTS		CAD FILE OUTLINE	SHEET 1 OF 1