

ENVELOPE / ASSEMBLY DRAWING

000000

SPECIFICATION CONTROL DRAWING

THIS DRAWING CONTAINS INFORMATION PROPRIETARY TO RF INDUSTRIES, LTD. ANY UNAUTHORIZED USE OF THIS DRAWING IS EXPRESSLY PROHIBITED. ANY VIOLATION IS PUNISHABLE UNDER U.S. COPYRIGHT LAWS.

REV	DESCRIPTION	DWN	DATE	APPROVED
C	ADD NUT AND BODY CALL OUTS	KMM	8/30/94	R. RICE
D	UPDATE \ CHANGE DIMS \ SEPARATE BODY IN DWG	KMM	6/3/97	R. RICE
E	ADD CLAMP DIM / CHG STRIPPING INST	CZS	6/19/98	R. RICE
F	STANDARDIZE SHELL & BODY / CHG DIE ID & STRIP INSTR	CZS	2/9/99	R. RICE

ALL DIMENSIONS ARE REFERENCE ONLY

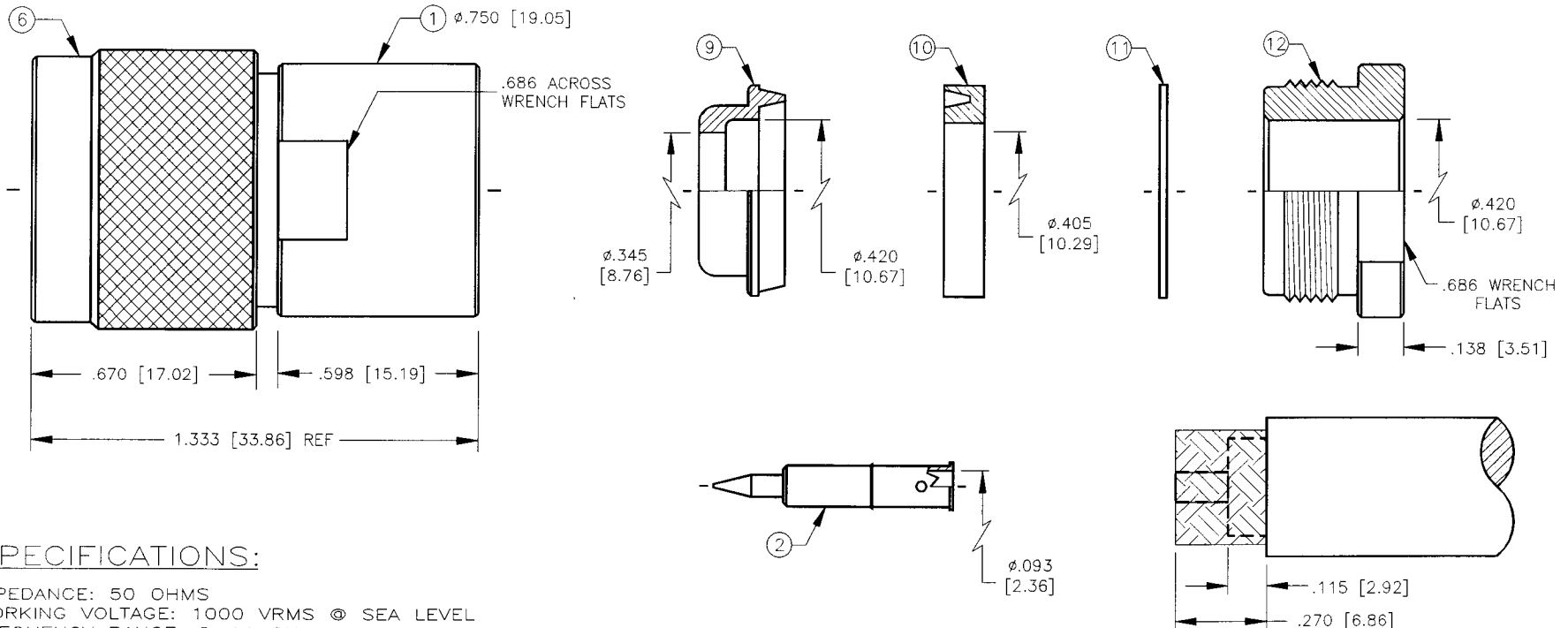

SPECIFICATIONS:

IMPEDANCE: 50 OHMS
 WORKING VOLTAGE: 1000 VRMS @ SEA LEVEL
 FREQUENCY RANGE: 0-11 GHz
 INSERTION LOSS: ≤ -.2 dB @ 10 GHz
 VSWR MAX: 1.3:1 @ 9 GHz
 FOR RG-8, 8A, 213/U, BELDEN 8237, 8267, 9251 & 9880
 INTERFACE PER MIL-STD-348A, SECTION 304.1

SUGGESTED STRIPPING INSTRUCTIONS
 SUGGESTED DIE: .100

ITEM	DESCRIPTION	QTY	MATERIAL	FINISH
12	END NUT	1	BRASS	SILVER
11	WASHER	1	BRASS	SILVER
10	GASKET	1	S.I. RUBBER	RED
9	CLAMP	1	BRASS	SILVER
8	PRESS FIT WASHER	1	BRASS	SILVER
7	RETAINING RING	1	BRASS	NONE
6	SHELL	1	BRASS	SILVER
5	GASKET	1	S.I. RUBBER	RED
4	GROUND RING	1	BRASS	SILVER
3	DIELECTRIC	1	TEFLON	NONE
2	PIN (PIN-305-10)	1	BRASS	GOLD
1	BODY	1	BRASS	SILVER

DIMENSIONS ARE IN INCHES AND [MILLIMETERS]	
UNLESS OTHERWISE NOTED TOLERANCES ARE:	
DECIMALS	DIAMETER
DRAWN C. ZUNIGA	2/9/99
CHECKED <i>[Signature]</i>	2/10/99
OR'D DRAWN D. FRIAS	1/22/88
APPROVALS	DATE

RF connectors
 DIVISION OF RF INDUSTRIES, LTD.
 7610 MIRAMAR RD
 SAN DIEGO, CA 92126
 (619)549-6340
 (619)549-6345 FAX

RFN-1002-1S \ UG-21E/U

N MALE CLAMP

SIZE A	CABLE GROUP E	DWG NO. 7806	REV F
SCALE: 2:1		CAD FILE 13ARC B	SHEET 1 OF 1