

THIS DRAWING CONTAINS INFORMATION PROPRIETARY TO RF INDUSTRIES,
 ANY UNAUTHORIZED USE OF THIS DRAWING IS EXPRESSLY PROHIBITED
 WITHOUT WRITTEN PERMISSION FROM RF INDUSTRIES.
 ANY VIOLATION IS PUNISHABLE UNDER U.S. COPYRIGHT LAWS.

PART NO.

RFF-1402-08

REV	DESCRIPTION	DWN	DATE	APPROVED
-	ENGINEERING RELEASE	CZS	12/1/00	JDMc

ALL DIMENSIONS ARE REFERENCE ONLY

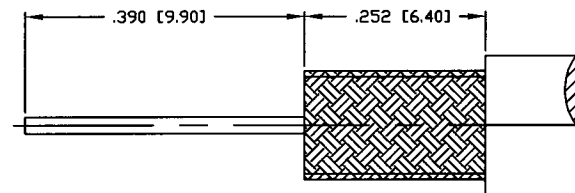
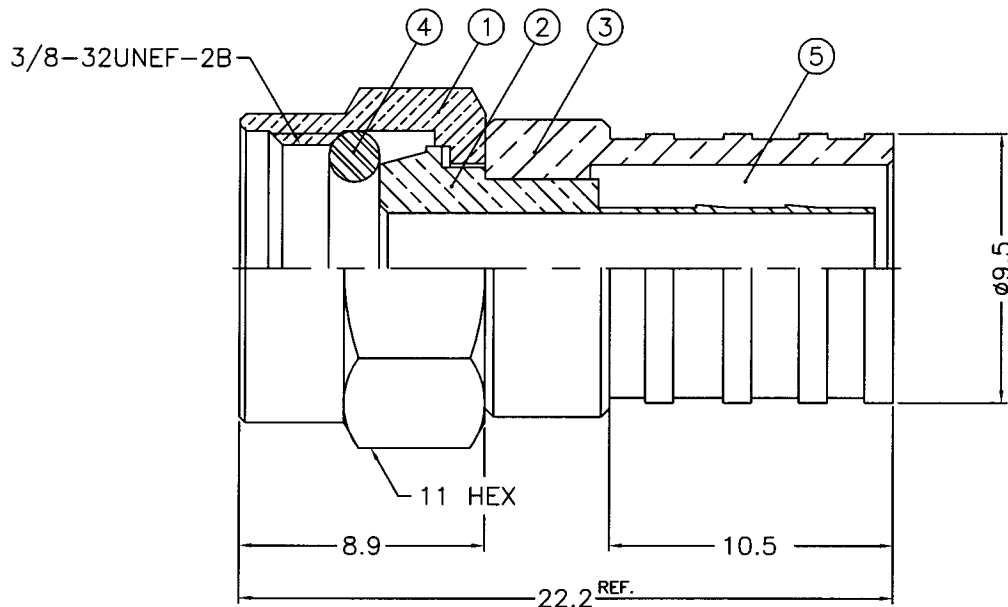

RECOMMENDED STRIPPING DIMENSIONS

CRIMP FERRULE,
 HEX CRIMP SIZE .324

SPECIFICATIONS:

IMPEDANCE: 75 Ohm
 FOR RG-6/U

1	BODY	1	BRASS	NICKEL / CHROMATE
2	FERRULE	1	BRASS	NICKEL / CHROMATE
3	GASKET	1	SILICONE	BLACK
4	SHELL	1	BRASS	NICKEL / CHROMATE
5	SILICONE GEL			CLEAR
6				
7				
8				
9				
10				
11				
12				
13				
14				
#	DESCRIPTION	QTY	MATRL	FINISH

000367	
DRAWN	JDM
CHECKED	<i>JDM</i>
ORJ DRAWN	C. ZUNIGA
APPROVALS	DATE
	12/1/00
	12/1/00

UNLESS OTHERWISE SPECIFIED:

1. REMOVE ALL BURRS
2. BREAK ALL CORNERS & EDGES .005 R. MAX.
3. CHAMFER 1ST & LAST THREADS 45°
4. SURFACE ROUGHNESS 63 FINISH MIL-STD-10
5. DIAMETERS ON COMMON CENTERS TO BE CONCENTRIC WITHIN .002 T.I.R.
6. ALL DIMENSIONS ARE AFTER PLATING.

DIMENSIONS ARE IN MILLIMETERS
 UNLESS OTHERWISE NOTED
 TOLERANCES ARE:

DECIMALS	DIAMETER
.xxx±.003 [.08]	.xxx±.001 [.03]
.xx±.005 [.13]	.xx±.003 [.08]

RF connectors
 DIVISION OF RF INDUSTRIES, LTD.

7610 MIRAMAR RD
 SAN DIEGO, CA 92126
 (858) 549-6340
 (858) 549-6345 FAX

F. PLUG CRIMP

SIZE	CABLE GROUP	DWG NO.	REV
A	Q	RFF-1402-08	-
SCALE:	NTS	CAD FILE	OUTLINE
			SHEET 1 OF 1