

THIS DRAWING CONTAINS INFORMATION PROPRIETARY TO RF INDUSTRIES.
 ANY UNAUTHORIZED USE OF THIS DRAWING IS EXPRESSLY PROHIBITED
 WITHOUT WRITTEN PERMISSION FROM RF INDUSTRIES.
 ANY VIOLATION IS PUNISHABLE UNDER U.S. COPYRIGHT LAWS.

ALL DIMENSIONS ARE REFERENCE ONLY

PART NO.		RFB-1717-Q		
REV	DESCRIPTION	DWN	DATE	APPROVED
-	ENGINEERING RELEASE	CZS	2/11/03	JDMc

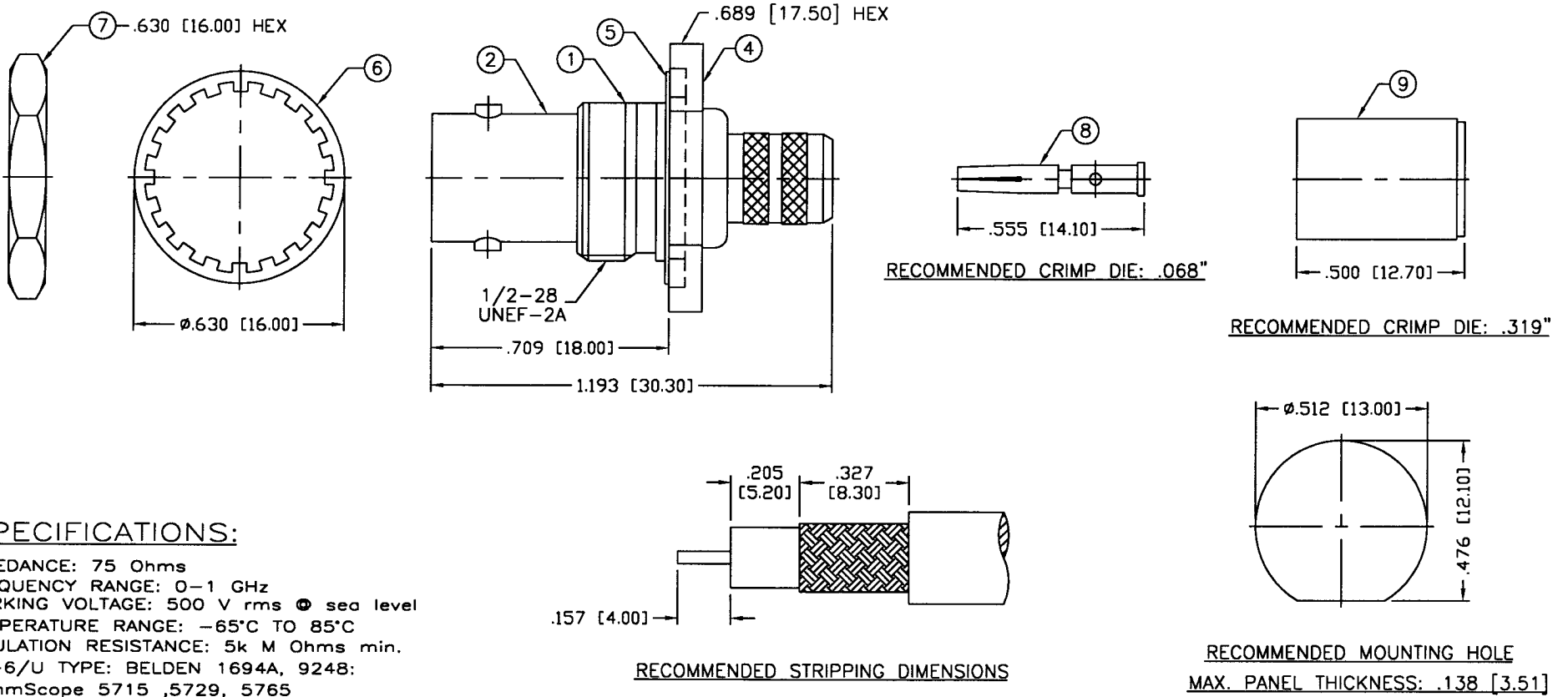

SPECIFICATIONS:

IMPEDANCE: 75 Ohms
 FREQUENCY RANGE: 0-1 GHz
 WORKING VOLTAGE: 500 V rms @ sea level
 TEMPERATURE RANGE: -65°C TO 85°C
 INSULATION RESISTANCE: 5k M Ohms min.
 RG-6/U TYPE: BELDEN 1694A, 9248:
 CommScope 5715 ,5729, 5765

1	BODY	1	BRASS	NICKEL, 100μ"
2	PRESS BODY	1	BRASS	NICKEL, 100μ"
3	INSULATOR	1	PTFE	---
4	FERRULE STUD	1	BRASS	NICKEL, 100μ"
5	GASKET	1	RUBBER	---
6	LOCK WASHER	1	BRASS	NICKEL, 100μ"
7	HEX NUT	1	BRASS	NICKEL, 100μ"
8	CONTACT	1	PHOS BRONZE	GOLD, 3μ"
9	FERRULE	1	BRASS	NICKEL, 100μ"
10				
11				
12				
13				
14				
#	DESCRIPTION	QTY	MATERIAL	FINISH

008974	DRAWN C. ZUNIGA CHECKED <i>CW</i> ORJ DRAWN C. ZUNIGA	5/28/03 <i>52903</i> 5/28/03
APPROVALS	DATE	

UNLESS OTHERWISE SPECIFIED:

- REMOVE ALL BURRS
- BREAK ALL CORNERS & EDGES .005 R. MAX.
- CHAMFER 1ST & LAST THREADS 45°
- SURFACE ROUGHNESS 63 FINISH MIL-STD-10
- DIAMETERS ON COMMON CENTERS TO BE CONCENTRIC WITHIN .002 T.I.R.
- ALL DIMENSIONS ARE AFTER PLATING.

DIMENSIONS ARE IN INCHES AND [MILLIMETERS]
 UNLESS OTHERWISE NOTED TOLERANCES ARE:

DECIMALS	DIAMETER
.xxx±.003 [.08]	.xxx±.001 [.03]
.xx±.005 [.13]	.xx±.003 [.08]

7610 MIRAMAR RD
 SAN DIEGO, CA 92126
 (858) 549-6340
 DIVISION OF RF INDUSTRIES, LTD. (858) 549-6345 FAX

BNC JACK, CRIMP

BULKHEAD

SIZE A	CABLE GROUP N/A	DWG NO. RFB-1717-Q	REV -
SCALE: NTS		CAD FILE OUTLINE	SHEET 1 OF 1