

THIS DRAWING CONTAINS INFORMATION PROPRIETARY TO RF INDUSTRIES,
 ANY UNAUTHORIZED USE OF THIS DRAWING IS EXPRESSLY PROHIBITED
 WITHOUT WRITTEN PERMISSION FROM RF INDUSTRIES.
 ANY VIOLATION IS PUNISHABLE UNDER U.S. COPYRIGHT LAWS.

ALL DIMENSIONS ARE REFERENCE ONLY

PART NO.		RFB-1707-D3		
REV	DESCRIPTION	DWN	DATE	APPROVED
-	ENGINEERING RELEASE	GGG	12/24/99	JDMc

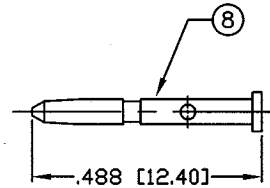
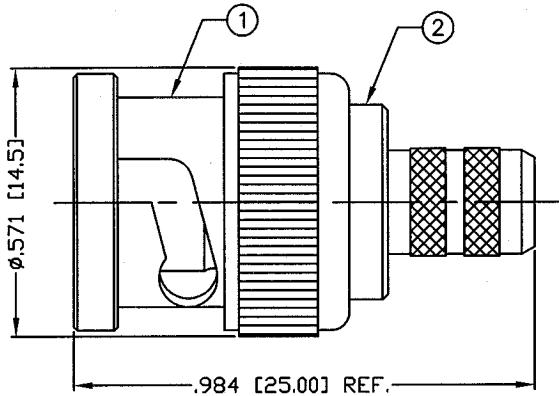

RECOMMENDED CRIMP DIE .042

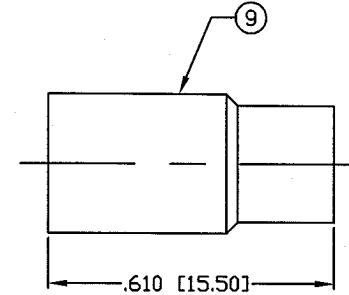

RECOMMENDED CRIMP DIE .255

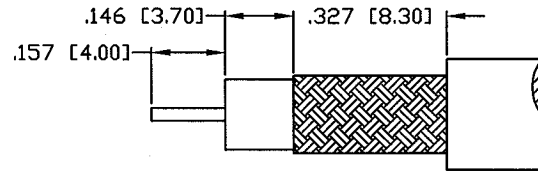

RECOMMENDED STRIPPING DIMENSIONS

SPECIFICATIONS:

IMPEDANCE: 75 Ohms
 FREQUENCY RANGE: 0-2 GHz
 WORKING VOLTAGE: 500 V rms max. @ sea level
 TEMPERATURE RANGE: -65°C TO 85°C
 INSULATION RESISTANCE: 5k M Ohms min.
 FOR: RG-59/U Type; Belden 1506A, 1825A, 1826A, 82108,
 89108, 89259; CommScope 2045, 2045V, 2065V

1	SHELL	1	BRASS	NICKEL, 100 μ^2
2	BODY	1	BRASS	NICKEL, 100 μ^2
3	INSULATOR	1	PTFE	----
4	GASKET	1	RUBBER	----
5	RETAINIG RING	1	BRASS	NICKEL, 100 μ^2
6	SPRING	2	SK5	NICKEL, 200 μ^2
7	WASHER	1	BRASS	NICKEL, 100 μ^2
8	PIN	1	BRASS	GOLD, 15 μ^2
9	FERRULE	1	BRASS	NICKEL, 100 μ^2
10				
11				
12				
13				
14				
#	DESCRIPTION	QTY	MATRL	FINISH

008974	DRAWN	G. GALLEGOS	10/19/01
	CHECKED	<i>[Signature]</i>	10-25-01
	ORJ DRAWN	G. GALLEGOS	10/19/01
	APPROVALS		DATE

UNLESS OTHERWISE SPECIFIED:
 1. REMOVE ALL BURRS
 2. BREAK ALL CORNERS & EDGES .005 R. MAX.
 3. CHAMFER 1ST & LAST THREADS 45°
 4. SURFACE ROUGHNESS 63 FINISH MIL-STD-10
 5. DIAMETERS ON COMMON CENTERS TO BE CONCENTRIC WITHIN .002 T.I.R.
 6. ALL DIMENSIONS ARE AFTER PLATING.

DIMENSIONS ARE IN INCHES AND [MILLIMETERS]
 UNLESS OTHERWISE NOTED TOLERANCES ARE:
 DECIMALS DIAMETER
 .xxx±.003 [.08] .xxx±.001 [.03]
 .xx±.005 [.13] .xx±.003 [.08]

RF connectors
 DIVISION OF RF INDUSTRIES, LTD.

7610 MIRAMAR RD
 SAN DIEGO, CA 92126
 (858) 549-6340
 (858) 549-6345 FAX

BNC PLUG, CRIMP

SIZE	CABLE GROUP	DWG NO.	REV
A	D3	RFB-1707-D3	-
SCALE:	NTS	CAD FILE	OUTLINE
			SHEET 1 OF 1