

# SPECIFICATION CONTROL DRAWING

THIS DRAWING CONTAINS INFORMATION PROPRIETARY TO RF INDUSTRIES, LTD. ANY UNAUTHORIZED USE OF THIS DRAWING IS EXPRESSLY PROHIBITED. ANY VIOLATION IS PUNISHABLE UNDER U.S. COPYRIGHT LAWS.

REV	DESCRIPTION	DWN	DATE	APPROVED
A	ENGINEERING RELEASE	MP	1/29/87	J. BENZ
B	ENGINEERING RELEASE	TF	7/25/91	J. BENZ
C	REVISE DRAWING THROUGHOUT / REMOVE O RING	KMM	8/10/98	R. RICE
D	CHG MATERIAL, SLOT LENGTH & OD OF CONTACT	KMM	9/21/98	R. RICE

ALL DIMENSIONS ARE REFERENCE ONLY

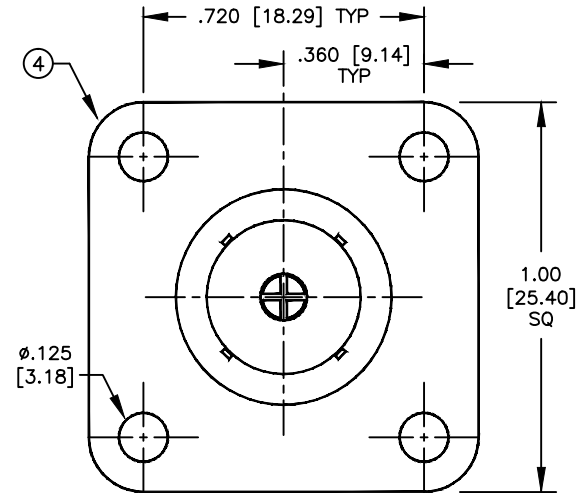
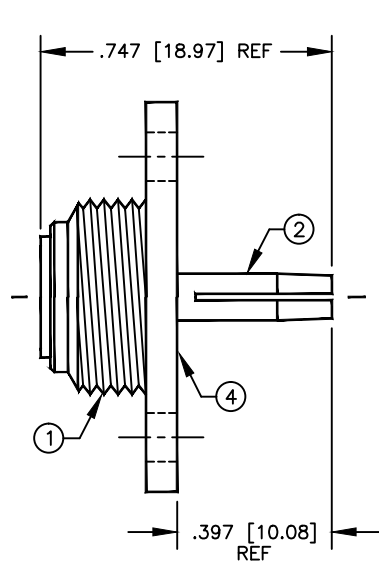

## SPECIFICATIONS:

DIMENSIONS ARE IN INCHES AND [MILLIMETERS]

UNLESS OTHERWISE NOTED TOLERANCES ARE:  
DECIMALS      DIAMETER

*RFconnectors*

DIVISION OF RF INDUSTRIES, LTD.

7610 MIRAMAR RD  
SAN DIEGO, CA 92126  
(619)549-6340  
(619)549-6345 FAX

## PT-4010-002

UNIDAPT FLANGE ADAPTER FOR  
TELEWAVE 44 OR 44A WATTMETER

ITEM	DESCRIPTION	QTY	MATERIAL	FINISH
4	FLANGE	1	BRASS	SILVER
3	DIELECTRIC	1	PTFE	NONE
2	CONTACT	1	PHOS BRONZE	GOLD
1	BODY	1	BRASS	SILVER

DRAWN K. MAXWELL	9/21/98
CHECKED	
ORJ DRAWN MP	4/10/87
APPROVALS	DATE

SIZE A	CABLE GROUP N/A	DWG NO. 8929	REV D
SCALE: 2:1		CAD FILE 13ARC B	SHEET 1 OF 1