

SPECIFICATION CONTROL DRAWING

THIS DRAWING CONTAINS INFORMATION PROPRIETARY TO RF INDUSTRIES, LTD. ANY UNAUTHORIZED USE OF THIS DRAWING IS EXPRESSLY PROHIBITED. ANY VIOLATION IS PUNISHABLE UNDER U.S. COPYRIGHT LAWS.

REV	DESCRIPTION	DWN	DATE	APPROVED
A	ENGINEERING RELEASE	SS	8/14/89	-
B	UPDATE DRAWING	CZS	1/13/98	R. RICE

ALL DIMENSIONS ARE REFERENCE ONLY

008974

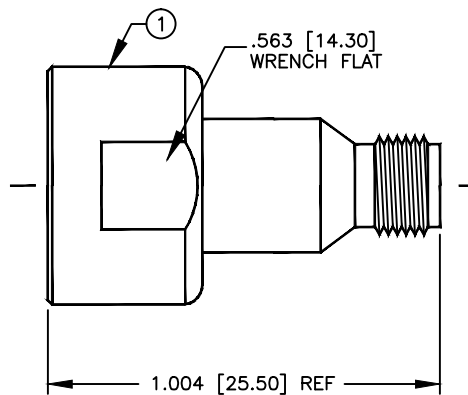

SPECIFICATIONS:

IMPEDANCE: 50 OHMS
 WORKING VOLTAGE: 335 VRMS @ SEA LEVEL
 FREQUENCY RANGE: 12.4 GHz
 INSERTION LOSS: \leq -.2 dB
 VSWR MAX: 1.3:1

DIMENSIONS ARE IN INCHES AND [MILLIMETERS]

UNLESS OTHERWISE NOTED TOLERANCES ARE:

DECIMALS DIAMETER

RFconnectors
 DIVISION OF RF INDUSTRIES, LTD.

7610 MIRAMAR RD
 SAN DIEGO, CA 92126
 (619)549-6340
 (619)549-6345 FAX

PT-4000-012

UNIDAPT TO SMA FEMALE

ITEM	DESCRIPTION	QTY	MATERIAL	FINISH
5	PRESS FIT WASHER	1	BRASS	SILVER
4	DIELECTRIC	1	PTFE	NONE
3	DIELECTRIC	1	PTFE	NONE
2	CONTACT	1	PHOS BRONZE	GOLD
1	BODY	1	BRASS	SILVER

DRAWN	C. ZUNIGA	1/13/98
CHECKED		
ORJ DRAWN	S. SMITH	8/14/89

SIZE	CABLE GROUP	DWG NO.	REV
A	N/A	8848	B

ITEM	DESCRIPTION	QTY	MATERIAL	FINISH	APPROVALS	DATE	SCALE:	CAD FILE	SHEET	OF
							2:1	13ARC B	1	1