

CABLE ASSEMBLY INSTRUCTIONS

RFD-1605-2-L2

CONNECTOR

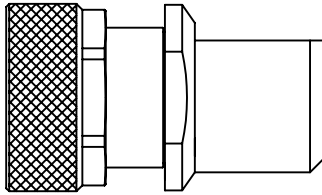

FERRULE STUD

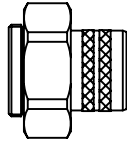

SCREW CAP



CRIMP FERRULE



STEP 2

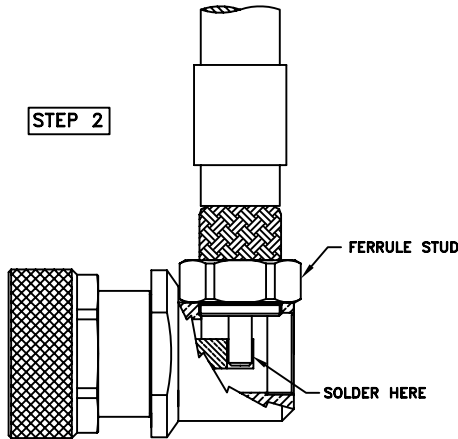

STEP 3

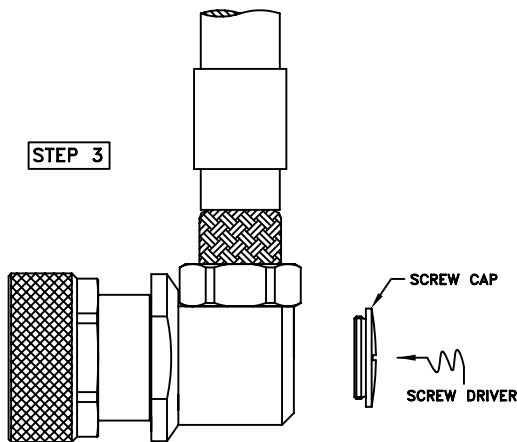

STEP 1

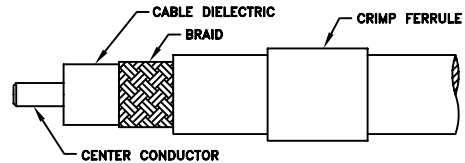

STEP 2

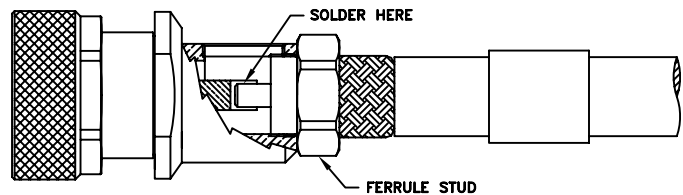

STEP 3

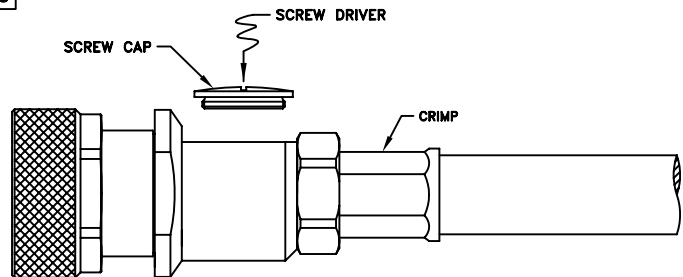

- Step 1:** Cut end of cable evenly. Strip cable to dimensions shown in catalog or outline drawing. All cuts are to be clean and square. Do not nick braid or center conductor when cutting. Slide ferrule over cable. If using strain relief or heat shrink tubing slide onto cable first.
- Step 2:** Screw ferrule stud into body in the desired configuration (straight or right angle.) Slide ferrule stud under braid, while inserting the cable into the body. Solder cable center conductor to center pin. If assembling it in the right angle configuration, cable center conductor should not extend past outer diameter of connector pin.
- Step 3:** Slide the crimp ferrule over the braid until it yields against the back of the connector. Crimp the ferrule with crimp tool as specified on connector drawing. Trim any extra braid extending out of ferrule end. Tighten "screw cap" using a flat head screw driver.

RFD-1605-2-L2 AP.DWG

RF CONNECTORS

4/25/07

7610 Miramar Road, San Diego, CA 92126-4202 - (858) 549-6340
 (800) 233-1728 - Fax (858) 549-6345 E-mail: rfi@rfindustries.com - www.rfindustries.com

CZ